



Intelligent Monitoring Device for Agricultural Greenhouse Using IOT

Pavithra G*

Department of Computer Science and Engineering, KS Institute of Technology, Bangalore, India

*Corresponding author: Pavithra G, Department of Computer Science and Engineering, KS Institute of Technology, Bangalore, India, Tel: 08028435722; E-mail: pavi.gurunathan@gmail.com

Rec date: March 23, 2018; Acc date: April 18, 2018; Pub date: April 30, 2018

Copyright: © 2018 Pavithra G. This is an open-access article distributed under the terms of the Creative Commons Attribution License, which permits unrestricted use, distribution, and reproduction in any medium, provided the original author and source are credited.

Abstract

Agriculture is the boon for any Country's economy and which has a strong bond between agricultural growth and economic prosperity. In this era, Smart Agriculture is not just a technology that eases the human life, but it has rather become a necessity or even a compulsion to cope with rapidly increasing food demand of the world population. The modern large-scale Greenhouse has been gradually built up in the Precision Agriculture (PA) domain. In Greenhouse, soil temperature, dampness and air temperature, dampness are the essential factors that influence the harvests development. The most imperative thing for rancher is to ace the Greenhouse condition in time, and afterward take powerful measures. The Internet of Things is the most encouraging innovation in horticultural applications which comprise of consistent of gadgets associated with screen and control the farming parameters. The proposed framework is utilized for irrigational checking and controlling utilizing remote sensor systems. The detected information can be checked, and the yield gadgets can be controlled utilizing IoT. Distinctive sensors are utilized for information obtaining. Detected information is conveyed to an Android Application gadget where a Monitoring Application makes them effortlessly open to screen and break down got information.

Keywords: Smart horticulture; Greenhouse screen; Smart water system; IoT; WSN

Introduction

Agriculture in India is still completed in customary way and falls behind in coordinating current innovations. Around 55 level of Indian populace has been occupied with agribusiness and partnered exercises which constitute just 15 percent of GDP, so it turns out to be much vital for the partners required to leave the traditional horticultural practices and modernize the farming utilizing innovation. The monetary commitment of horticulture to Indian economy is relentlessly declining with the nation's wide based financial development while extensive number of individuals keeps on working in rural segment. Consequently, there is a prompt need to enhance the framework, which can expand the yield and deliver sound natural sustenance.

Problem Statement

One of the most difficult issues is because of unequal dissemination of rain water, it is extremely hard to rancher to deal with the water similarly to every one of the products in entire homestead it requires some water system strategy that appropriate for any climate condition, soil writes and assortment of yields. Nursery is the best answer for this, yet for this rancher require nonstop following of a greenhouse to keep up every ecological condition that required for various harvests. On the off chance that there is any adjustment in the framework should change or keep up that progressions as indicated by agriculturist guideline [1].

Approach

Wireless Sensor Network (WSN)

Nodes of WSNs comprises of four key parts and of discretionary segments. The key segments are a power unit (batteries or/and elective source), a detecting unit (sensors and simple to-computerized converters), a handling unit (along with storage), and a handset unit (communication). Discretionary parts can be a limitation framework, an actuator, and other application subordinate segments. Basic for viable utilization of WSNs is lifetime of its independent hubs. Hubs depends for the most part on vitality source. In the most cases the source is a battery cell in particular cases it could be a sun based mechanical (vibration) or Thermal sources. Relative investigation was done to pick remote system correspondence include in the undertaking. Three kinds of remote associations were decided for examinations, which are GSM, Bluetooth and 3G (Table 1).

The accompanying are the three diverse remote units/modules which are ordered for different purposes:

Remote sensor unit: A few WSU are being sent in-field to design the circulated sensor arrange for robotized water system framework. WSU contains radio Frequency, handset, sensors, a microcontroller, and power sources.

Remote data unit: All information from WSU is been gotten, recognized, and broke down in WIU. It comprises of ace controller, GPRS module, and web application.

Watering module: The water system is performed by controlling the two pumps electromagnetic transfers associated with microcontroller.

	GSM	Bluetooth	3G
Range	35 km	10 km	20-32 km

Data Rate	9.6 kpbs	700 kbps	2 mbps
Media	Digital Data	Digital Data	Mainly Digital Data
Security	Moderate level	Moderate level	Moderate level

Table 1: Examination between 3 kinds of Wireless correspondence channels.

Sensors

Sensor station square chart is appeared in Figure 1. It comprises of microcontroller as a hart of sensor station which gives all the controlling stage to proposed framework by utilizing inputs sensors of temperature, moistness, light force and soil dampness sensor. The temperature of the dirt and within temperature of the nursery are interrelated parameters, which can be, control by legitimate setting of ventilation. Since the temperature control relies upon coordinate sun radiation and the screen material utilized, the best possible set point can change in accordance with control soil temperature. The temperature set-point esteem relies upon the genuine temperature of within and outside of the nursery. The accompanying are the distinctive sensors which are utilized: Temperature sensor, Humidity sensor, Soil sensor, Water-level sensor, Light Dependent Resistor (Figure 1).

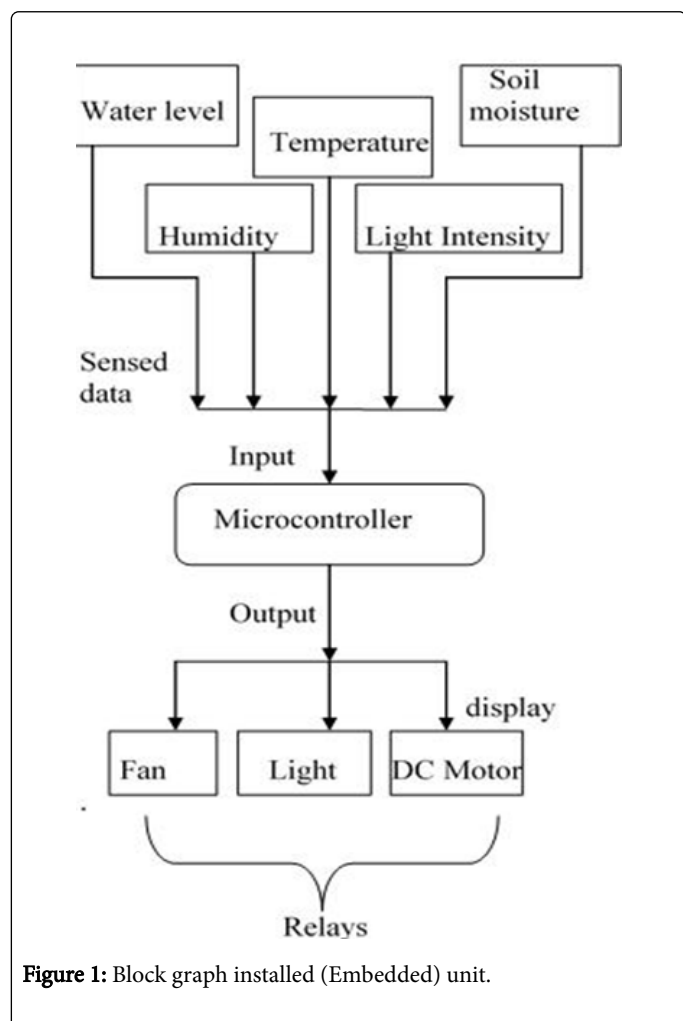

Figure 1: Block graph installed (Embedded) unit.

Temperature control: Growth of manor relies upon photosynthesis strategies that is relies on the radiation from the sun. Considering high radiation, temperature is expanding, and a few yields may get harmed, so it needs some ventilation strategy to control the temperature. In framework if the temperature is changes as indicated by that cooler or radiator will turn on.

Humidity control: Water vapor is fundamental issue that is influencing the development of products. Due to high humidity (mugginess), odds of ailment are expanding. Mugginess may cause hydria push, shutting the stomata and hence it might let down the procedure of photosynthesis which relies upon the osmosis. For moistness and temperature same controlling move will be made.

Soil control: Soil water likewise influences the yield development. Subsequently, the screen and control of soil condition have a intrigue, in light of the fact that the great state of dirt may produce the correct yield. The best possible water systems and preparations of the products are differed according to the sort, age, stage and atmosphere.

Water-level: The pH esteem, dampness contains, electric conductivity and the temp of dirt are some key parameters. The pH valves and different parameters will screen the dirt condition. The temperature and the dampness can be controlled by the water system strategies like float and sprinkle framework in a nursery.

Light dependent resistor: LDR or a photograph resistor is a photograph conductive sensor. It is a variable resistor and changes its protection in an extent to the light presented to it. Its protection diminishes with force of light.

Internet of Things (IoT)

Fundamental Block outline of framework IoT Internet of Things (IoT) is generally utilized as a part of associating gadgets and gathering information data. Web of Things is utilized with IoT systems to deal with and communicate with information and data. 'Web of Things' depends on gadget which is equipped for investigating the detected data and after that transmitting it to the client. Uses of IoT are Smart Cities, Smart Environment, Smart Water, Smart Metering, Security and Emergency, Industrial Control, Smart Agriculture, Home Automation, e-Health and so on.

It is additionally material for different farming territories, for example:

- Water quality observing.
- Screen soil constitute, soil moistness.
- Wise green houses.
- Water system.
- Logical malady and vermin checking.

Remote sensing in agriculture

Remote is a perception of an articles without really being in physical contact with it. Itemized recognizable proof from the earth and environment will be made considering the estimation or perception accumulated from the sensor. That computerized information was investigated more proficiently (show, upgrade and control) utilizing a PC (Figure 2) [2-4].

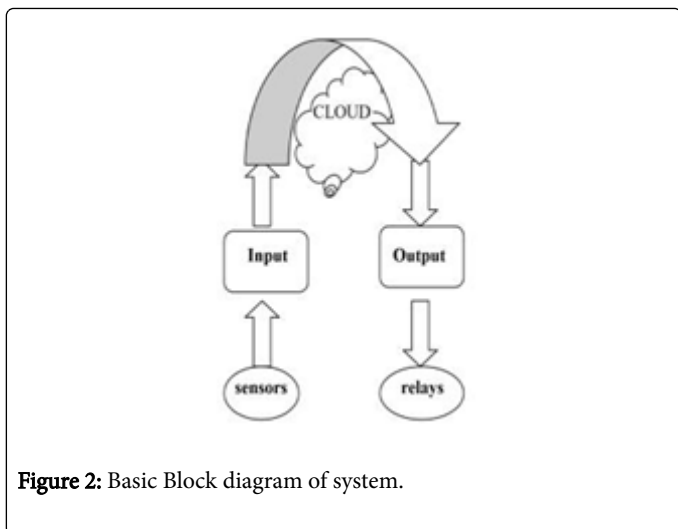

Figure 2: Basic Block diagram of system.

Remote monitoring in agriculture

- Absence of a simple UI.
- High cost.

Therefore, there's a requirement for a reasonable and simple to utilize natural observing gadgets that would ranchers to have simple access to factors. For example, Air temperature, Soil water, relative stickiness, and so on showing Functional Module (Figure 3). At present, remote detecting procedures are broadly found in the application, for example, change ponder, earth surface condition and asset review. However, considering the high costs of the strategies and the atmosphere consequences for procuring horticulture data a more proficient system is required.

For the enormous country fields, field information transmission by means of hard-wired frameworks and the web won't not be proper. Thusly, a pervasive remote framework to gather and transmit the field information is the more appropriate decision for exact cultivating application.

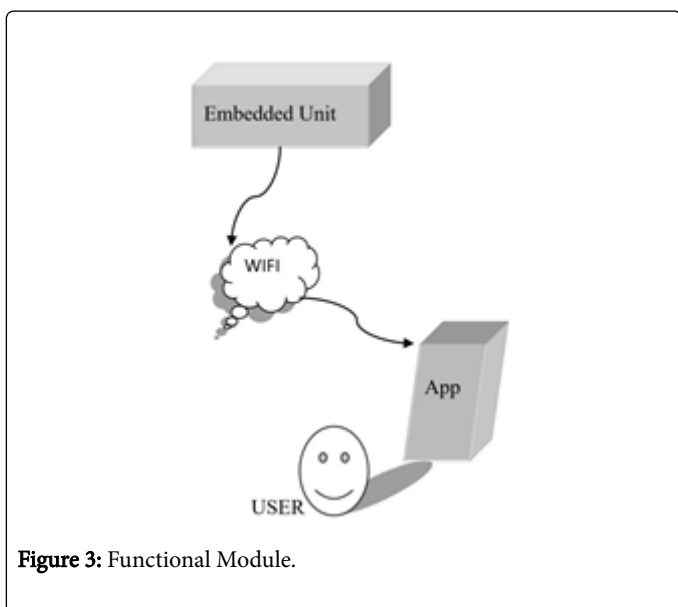

Figure 3: Functional Module.

Mobile phone

Two mobile phones (Cell Phone) will be utilized as a part of the examination venture, one is to be use as GSM modem to interface with PC and another telephone as customer to get alarm from the framework. To empower the telephone, go about as GSM modem, a cell phone with GSM empowered is required to be associated with PC introduced with SMS door so the framework will have the capacity to send and get message [5].

Essential Advantages

Saves water

Thinks about demonstrates that this sort of computerized water system framework expends 40-half less water when contrasted with the regular strategy.

Enhances growth

Perfect development condition is being given when little measure of water is being connected over huge measure of time. This savvy water system framework broadens watering time for plants and gives perfect development condition.

Spare time

In this, sprinklers moving, and setting isn't required consequently it spares time and clock delay according to the natural condition can be included for programmed watering.

Versatile

This savvy water system framework can be balanced and adjusted by the evolving condition.

Easier method

It is easy to work it begins by outlining the guide of your garden and denoting the area of planting. At that point the required separation is been estimated for length of plastic tubing with the goal that the coveted region can be come to.

Synopsis and Outlook

Summary in this paper Development of agribusiness is creating towards the course of data and computerization. This paper thinks about the clever administration of horticulture nursery in view of the Internet of things. Nursery is utilized for planting valuable organic products, vegetables and different harvests in a consistent temperature, dampness and other condition, the earth is especially vital for requesting crops.

In this paper, through a specific equipment and sensor innovation joined with programming innovation, influencing the control of nursery condition to can be accomplished through the type of versatile application, to encourage the chairman of the remote activity. In this paper, the principle utilization of equipment gets together and written work, Embedded c and different advancements.

Result Intelligent farming nursery is growing quickly lately, and it brings more considerations up in both modern and scholastic social orders. This paper takes a full thought of cost, practicability and

different elements, joining the cloud and Android innovation outlined a keen Greenhouse observing framework with stable execution, straightforward structure and simple extensibility.

Contrasted and customary Greenhouse condition checking frameworks, the framework has such points of interest as high dependability and versatility. Any Android upheld gadget can be utilized to introduce the Greenhouse, and control and screen nature inside the green house. A minimal effort Greenhouse checking and controlling framework has been produced which does not require a PC as all preparing is taken care of by the microcontroller, diminishing the wiring changes for introducing the proposed framework in prior green house by making a remote system inside the greenhouse condition for controlling and observing the greenhouse condition [6].

Affirmation

The creators enormously express gratitude toward Mrs.Sougandhika Narayan, Assistant Professor, Computer Science and Engineering, K.S. Institute of Technology, Bangalore for her full help reached out to do this extend.

References

1. Vatari S, Bakshi A, Thakur T (2016) Green house by using IOT and cloud computing. In Recent Trends in Electronics, Information & Communication Technology (RTEICT), IEEE International Conference, pp: 246-250.
2. Jie Y, Pei JY, Jun L, Yun G, Wei X (2013) Smart home system based on IOT technologies. In Computational and Information Sciences (ICCIS), Fifth International Conference, pp: 1789-1791.
3. Sliva J (2008) Technologies used in wireless sensor networks. In Systems, Signals and Image Processing, IWSSIP, 15th International Conference, pp: 77-80.
4. Sohraby K, Minoli D, Znati T (2007) Wireless sensor networks: technology, protocols, and applications. John Wiley and Sons.
5. Dan L, Xin C, Chongwei H, Liangliang J (2015) Intelligent agriculture greenhouse environment monitoring system based on IOT technology. In Intelligent Transportation, Big Data and Smart City (ICITBS), International Conference, pp: 487-490.
6. Hanggoro A, Putra MA, Reynaldo R, Sari RF (2015) Greenhouse monitoring and controlling using Android mobile application. In QiR (Quality in Research), International Conference, pp: 79-85.